

Towards a traceable infrastructure for low force metrology

Professor Richard Leach

Christopher Jones

Engineering Measurement Division

National Physical Laboratory

5 October 2009

What is 'traceability'?

- *Traceability* is the property of a measurement or the value of a standard whereby it can be related to stated references, usually national or international standards, through an unbroken chain of comparisons all having stated uncertainties.
- Highest level: the **International System of Units (SI)**
- UK National Measurement System (NMS): enables measurement traceability back to UK national standards.
- As the UK's national standards laboratory, NPL is at the pinnacle of this system guaranteeing the accuracy of physical measurements for the nation and abroad.

What is 'low force measurement'?

- newtons (1 N) → attonewtons (10^{-18} N)
- Quantitative characterisation of forces acting in or generated by micro- or nanostructures (e.g. MEMS, NEMS)
- Requires measurement
- ...which requires traceability to be useful.

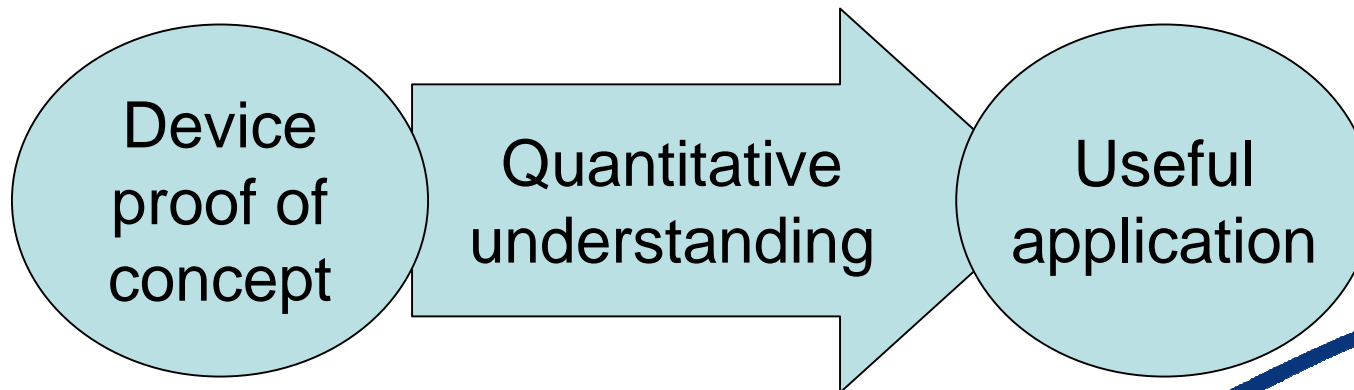

The force scale...and some applications

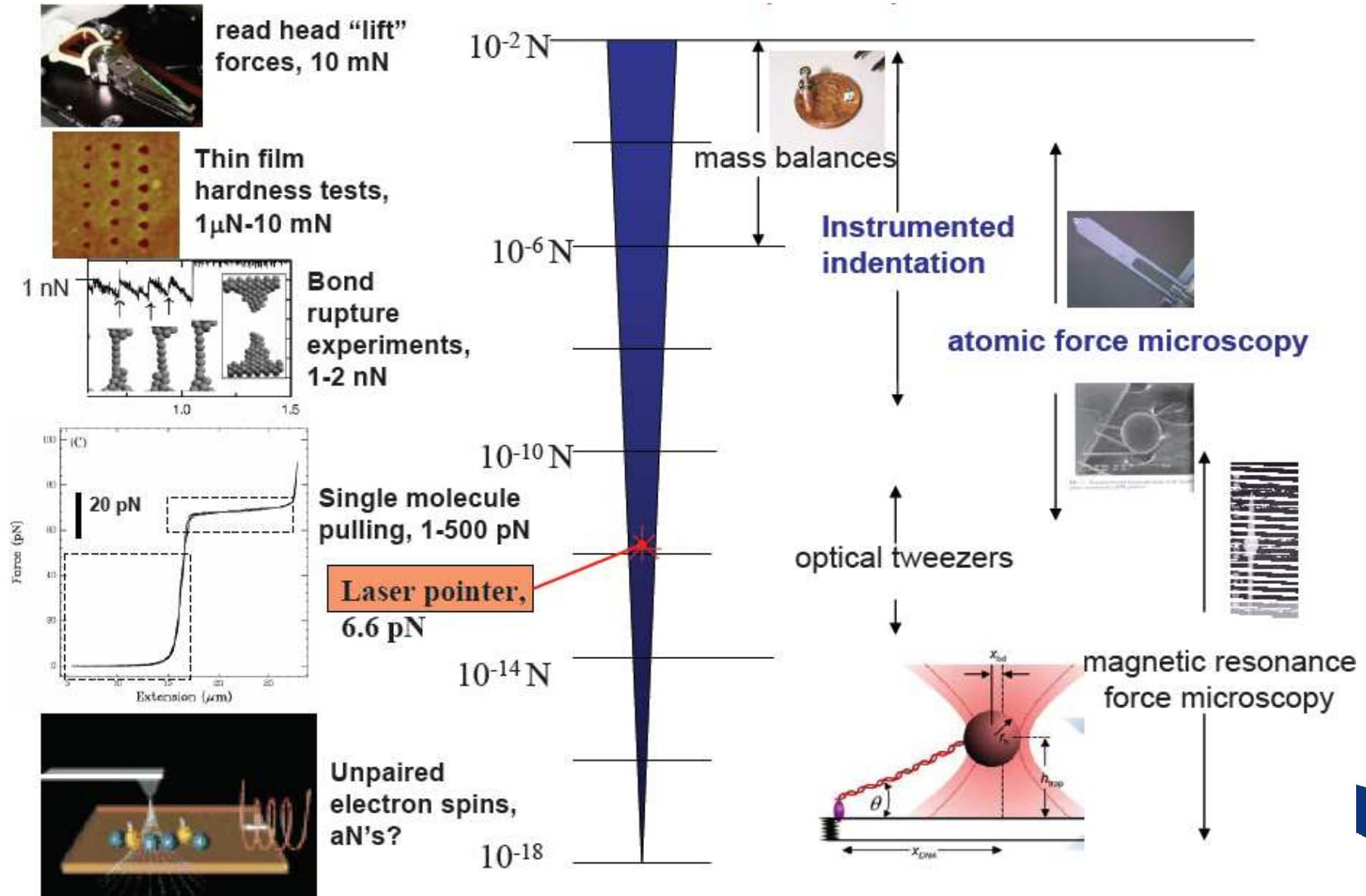

NPL low force facility

- Ill-defined interaction forces
- Ability to characterise
 - benefit to industry
 - Instrument manufacturers – competitiveness
 - MNT manufacturers – better quality control

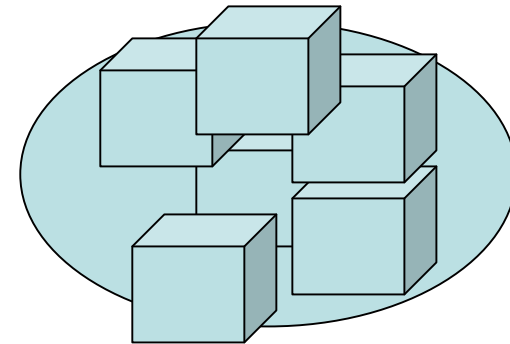

Target
instruments
in industry

Goal: much-improved traceability route
for low force measurement

NPL low force facility

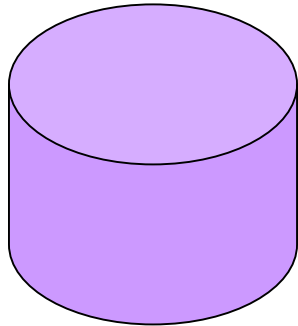

Primary standard:
best possible
force realisation

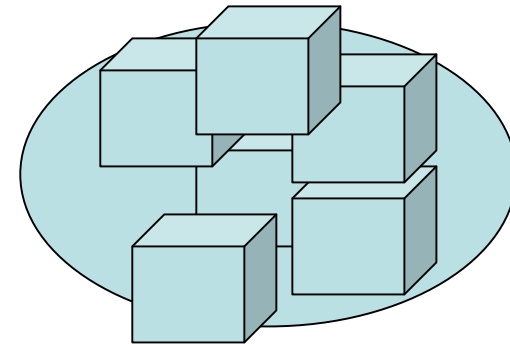

Target
instruments
in industry

Goal: much-improved traceability route
for low force measurement

NPL low force facility

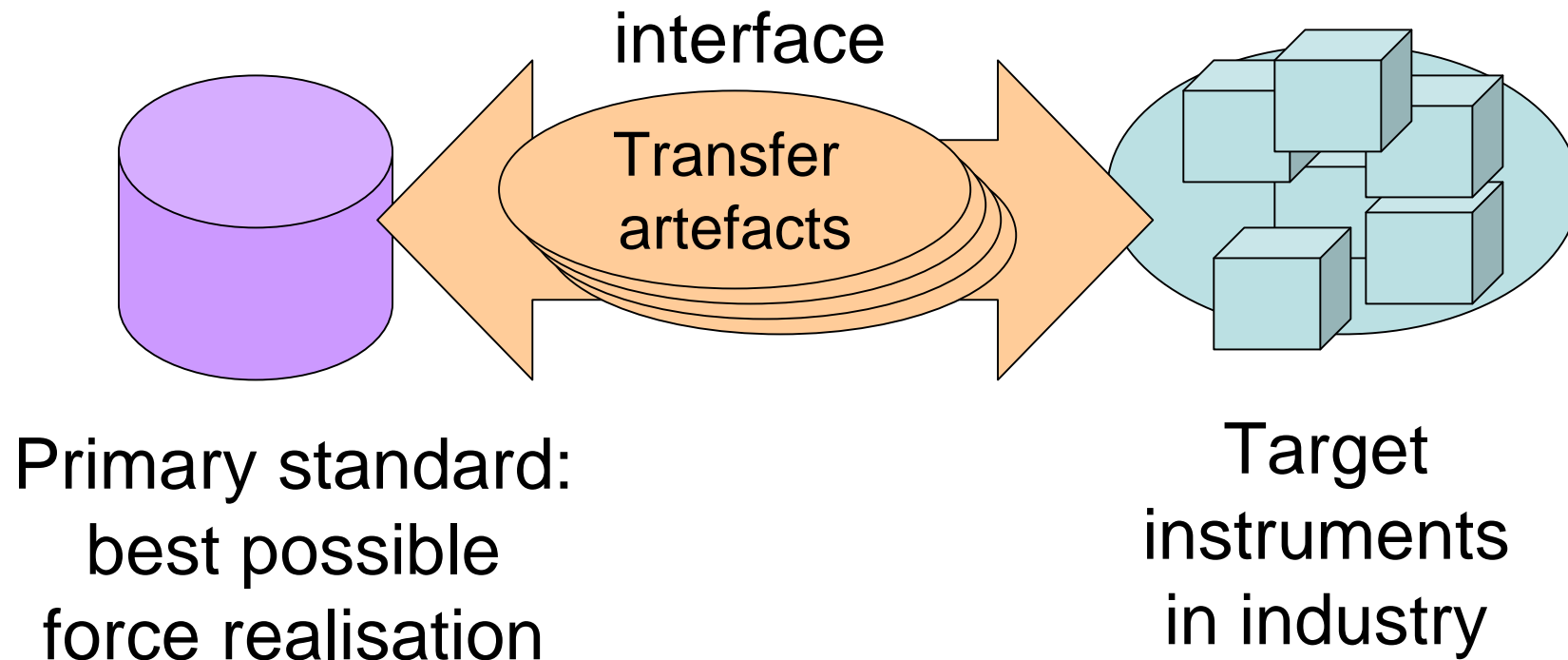

Goal: much-improved traceability route
for low force measurement

Beneficiaries

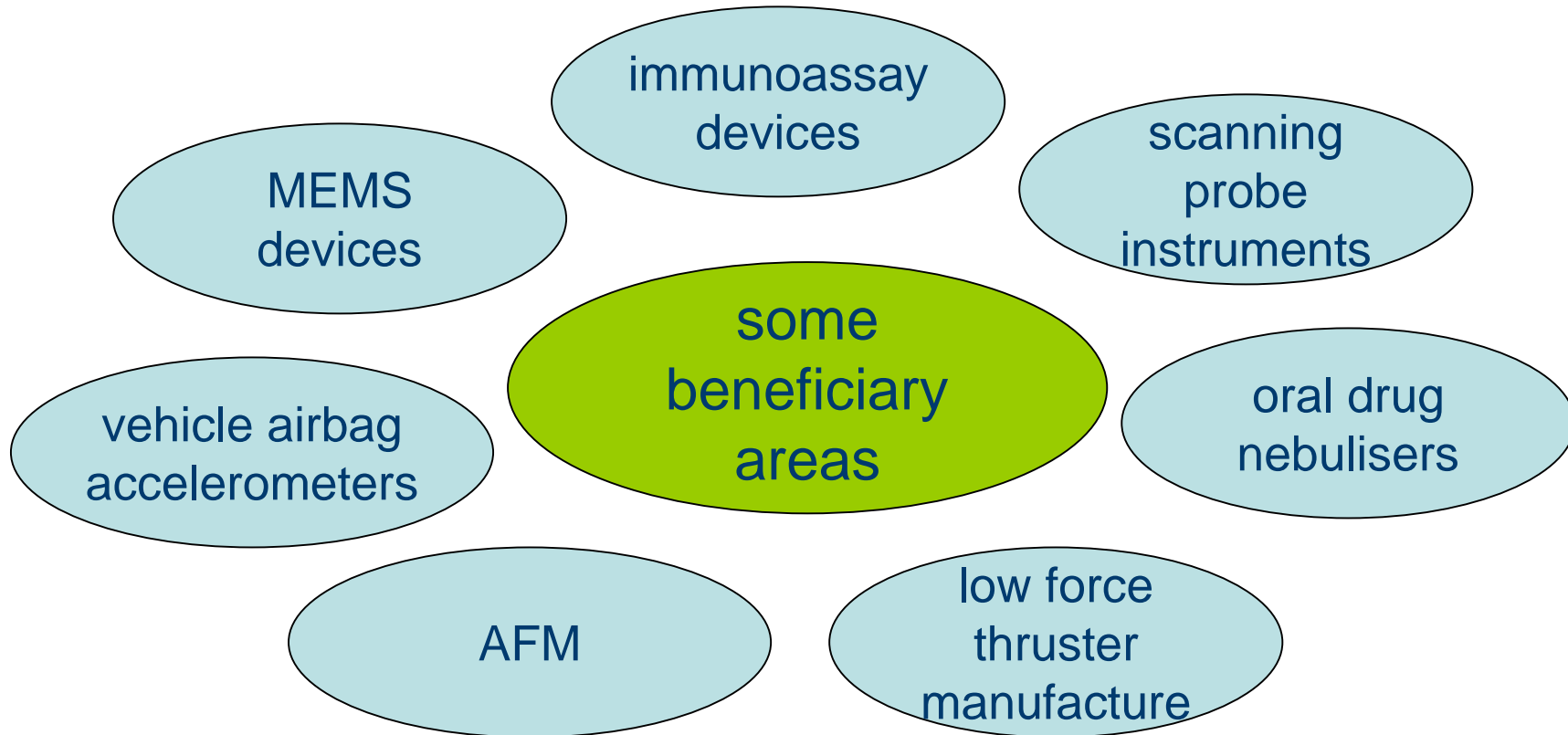

Deadweights: the traditional force standard

- Weight of a known mass
- $1 \text{ nN} \equiv 0.1 \text{ } \mu\text{g} \equiv 0.1 \text{ mm} \times 0.1 \text{ mm} \times 5 \text{ } \mu\text{m Al}$
.... not practical!
- Suitable for comparison only at NMIs
- Mass defined in terms of a lump of metal – not ideal
- Not future proof



The electrostatic force balance technique

- Balance input force with force generated between charged capacitor plates
- Traceability to fundamental constants

$$F = -\frac{1}{2}V^2 \frac{dC}{dz}$$

Quantum hall effect

c (speed of light)

Josephson effect

The NPL Low Force Balance

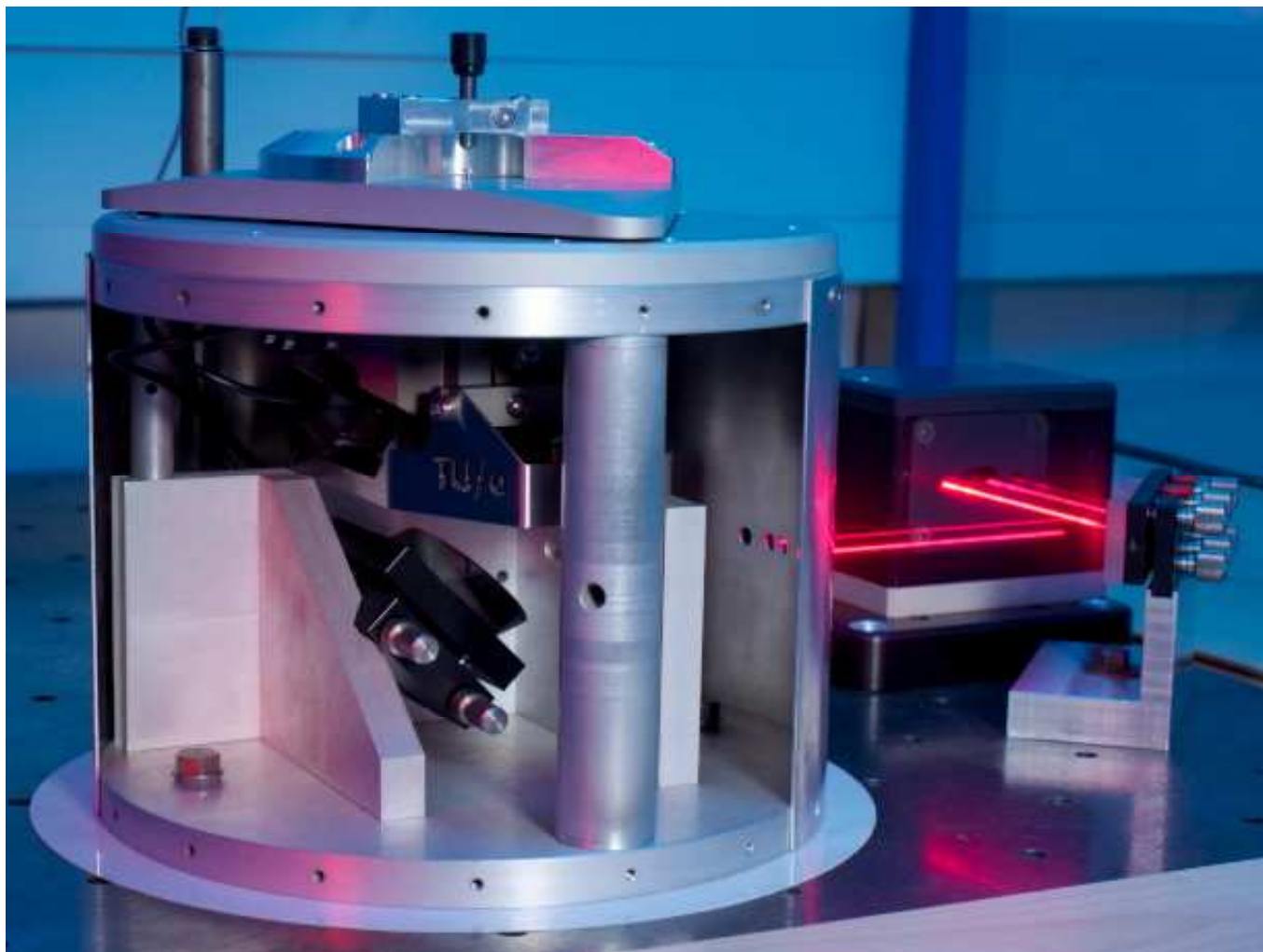

TU/e

The NPL LFB

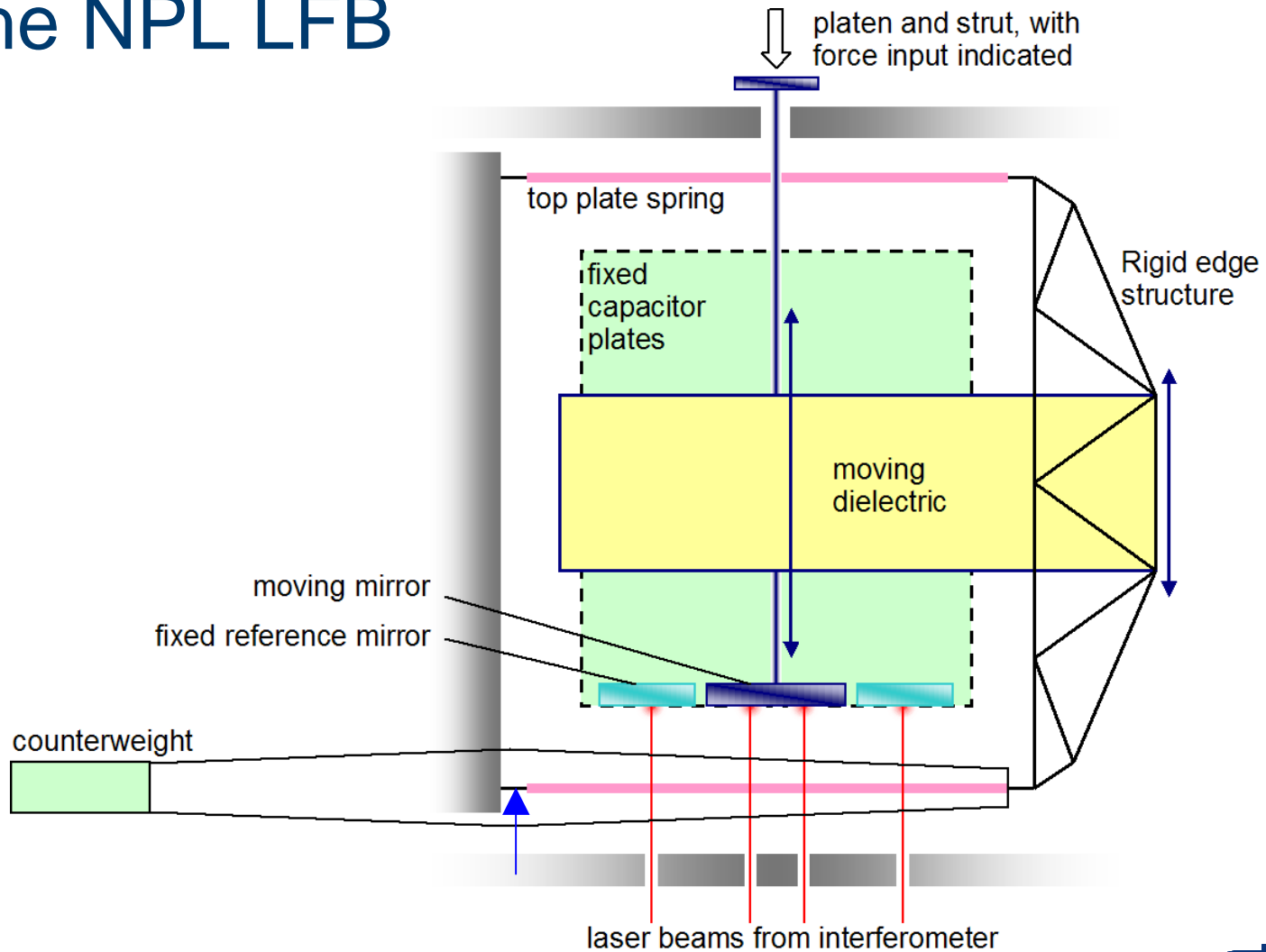

10 μN to 1 nN

International equivalents

- NIST, USA
 - ‘Electrostatic Force Balance’
 - Transfer artefacts
- PTB, Germany
 - Novel inverted pendulum design
 - Transfer artefacts
- KRISS, Korea
 - In-depth modelling of flexures
- International equivalents permit formal comparisons
 - increased measurement confidence
 - collaboration for better taxpayer value

Transfer artefact – requirements

- Outputs a faithful and repeatable analogue to an input force ... and vice versa
- Self-contained metrology
 - c.f. spring constant calibration devices
- Robust, yet compact
- Balance interface
 - Invertible
 - Tip design
 - No crosstalk

Transfer artefact – development (with University of Warwick)

- New artefact to exploit nN performance under development
 - Best performance through simplicity
 - Optimised for LFB interface

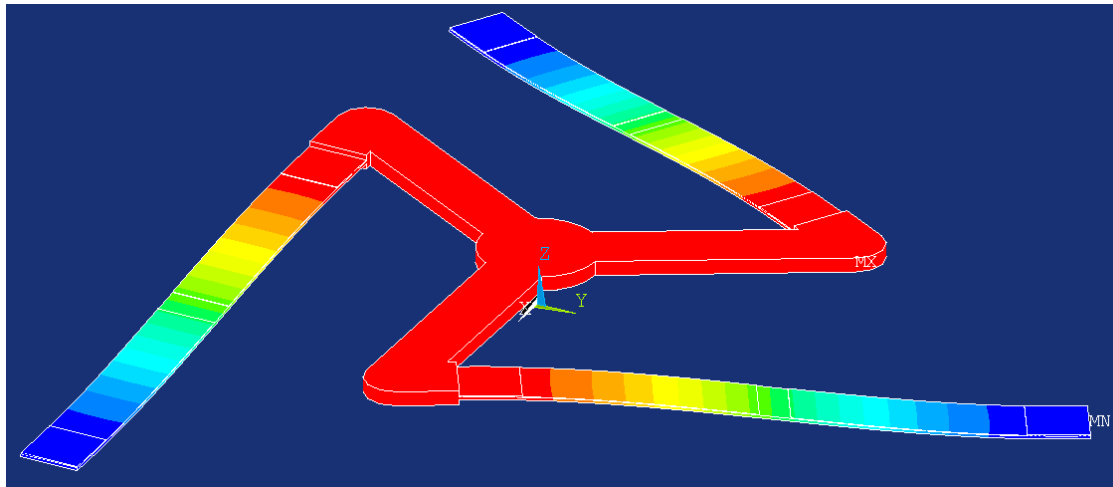

Transfer artefact – development

- Suite of NPL spring constant devices available for comparison and adapted use

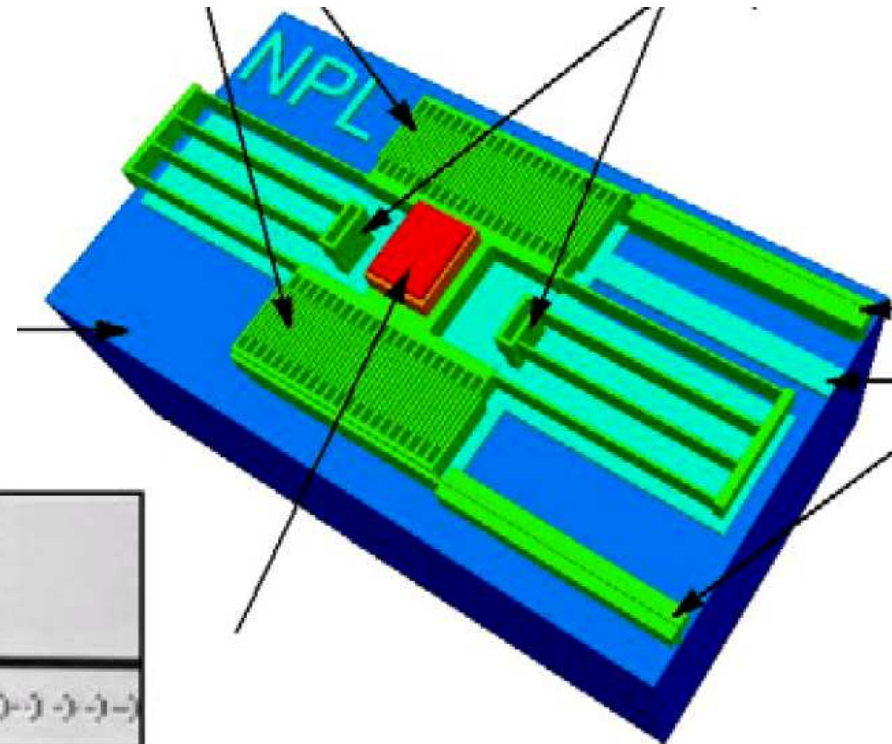
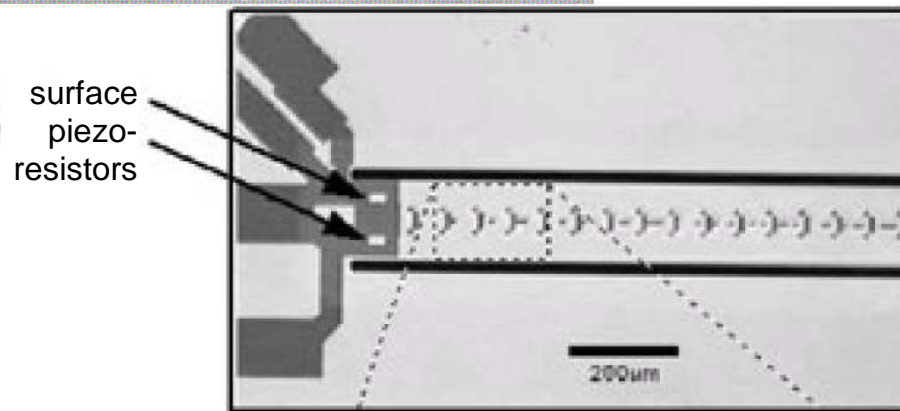
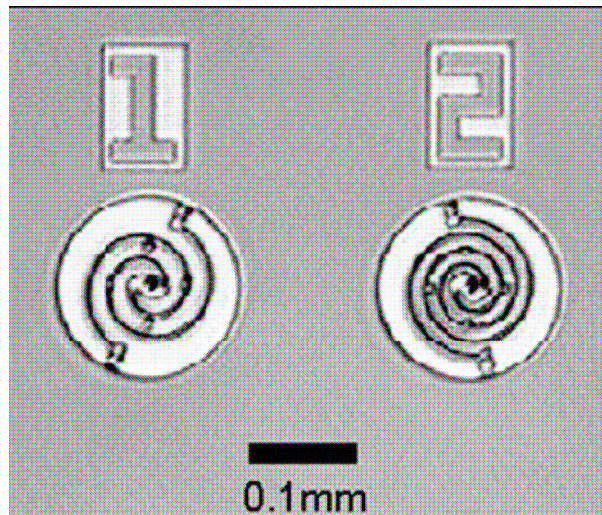

Transfer artefact – development

- Commercial devices – characterise for use
- Devices from international collaborators

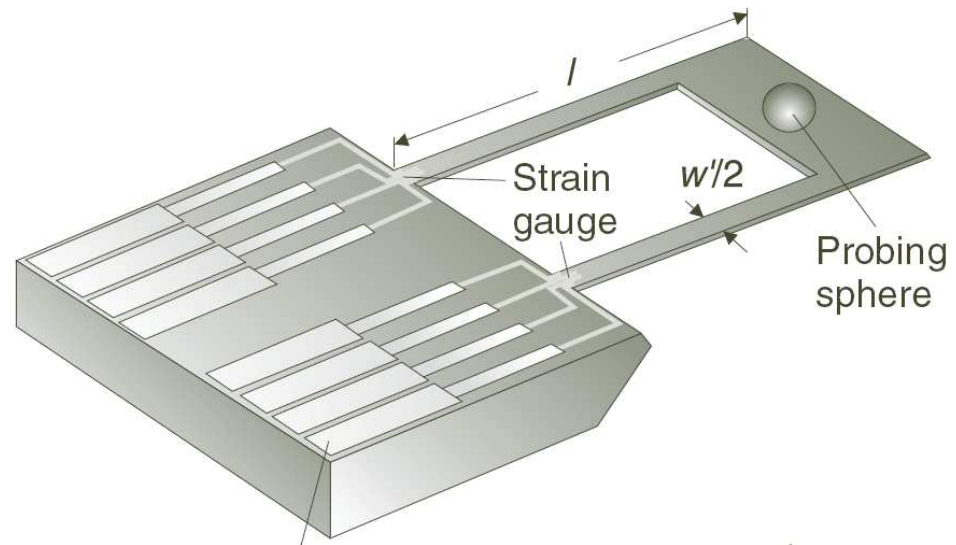
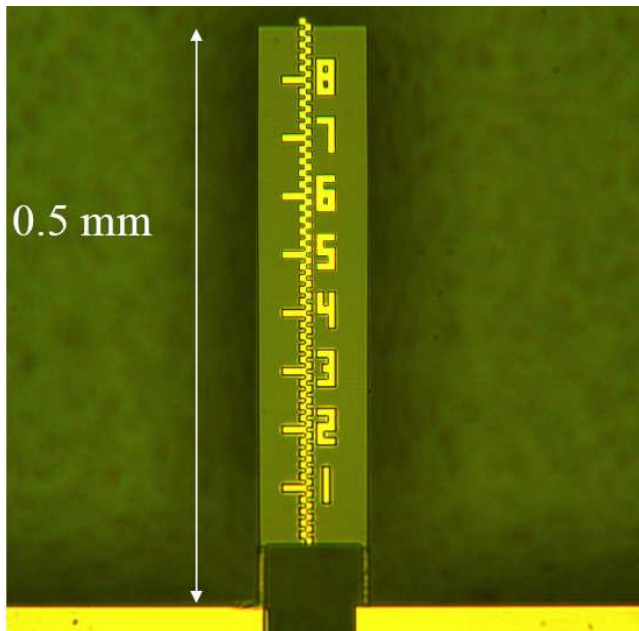

Future metrology

- Optical tweezers for force measurement

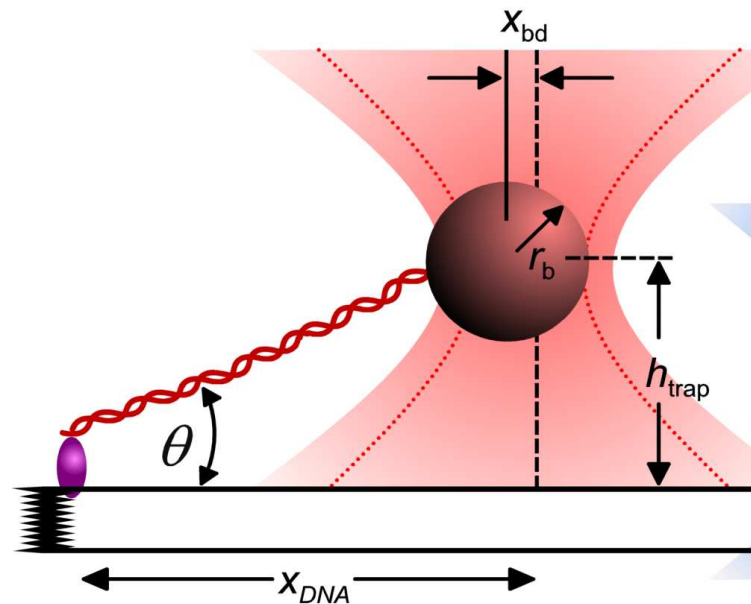

Future metrology

- Optical tweezers for force measurement

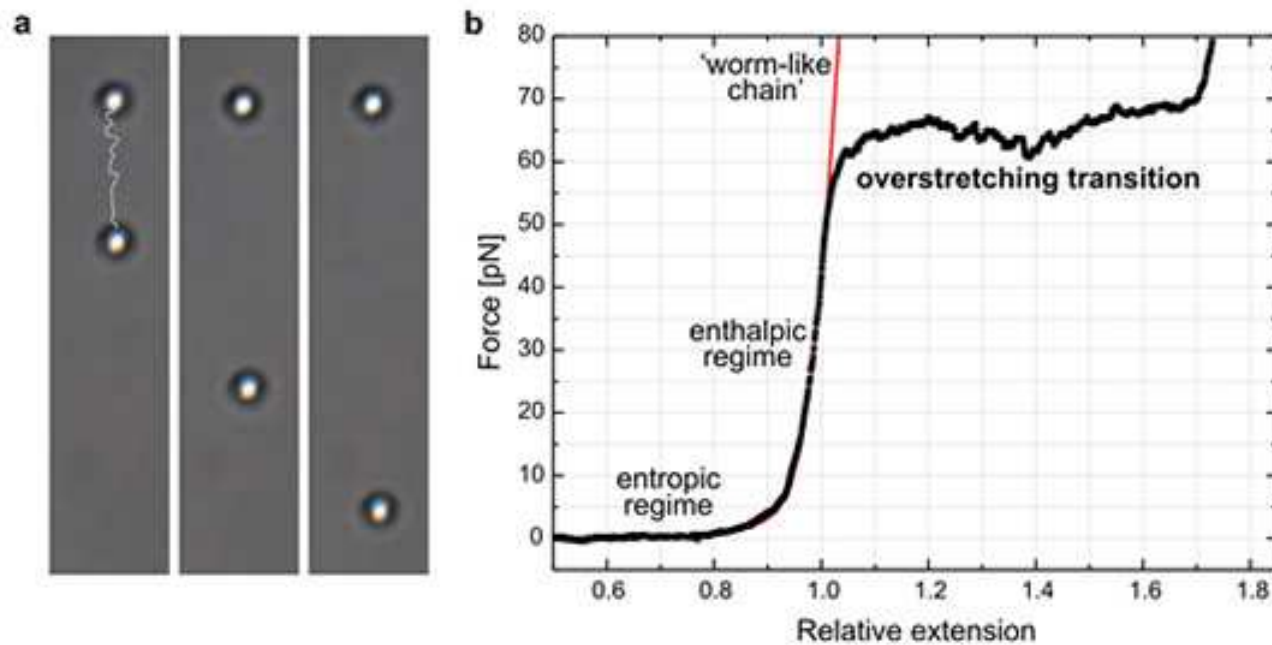

Future metrology

- Casimir effect

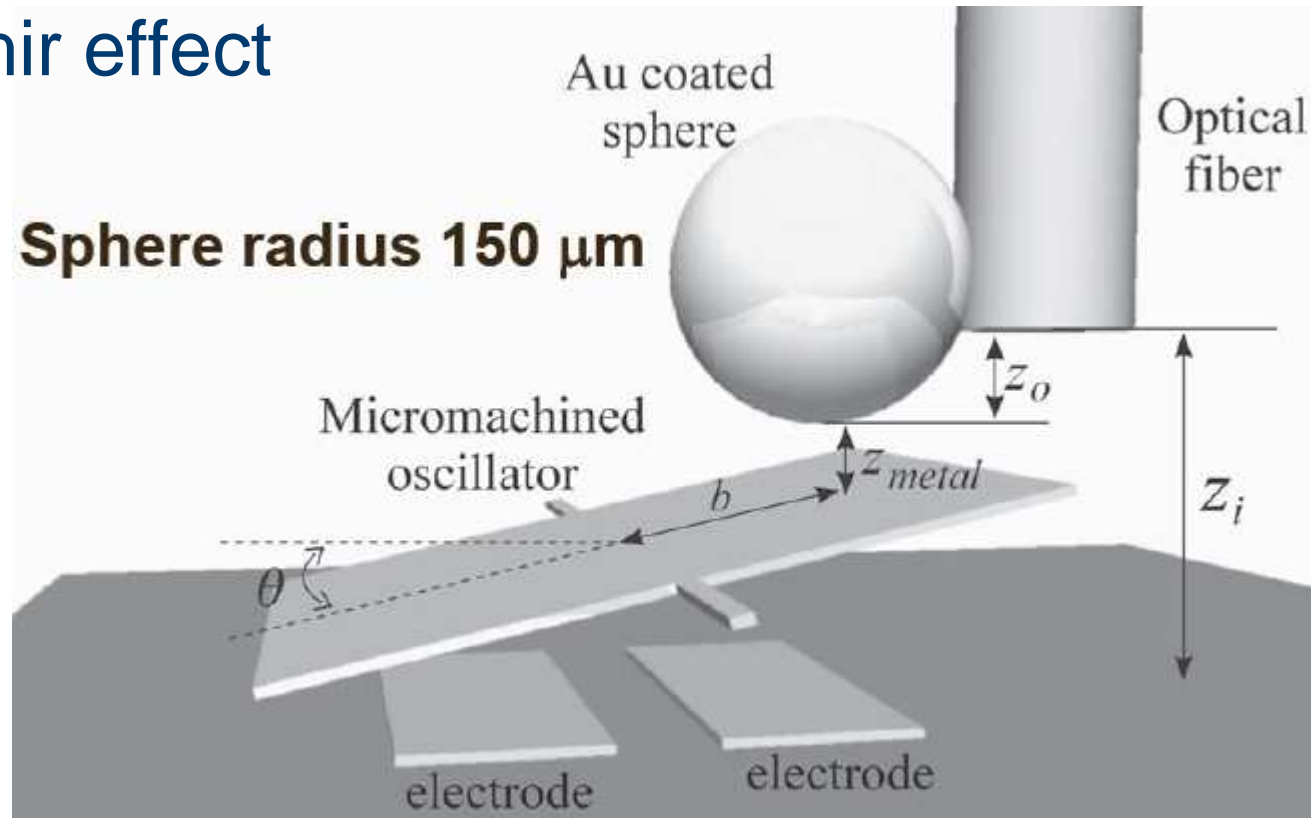

Future metrology

- Casimir effect

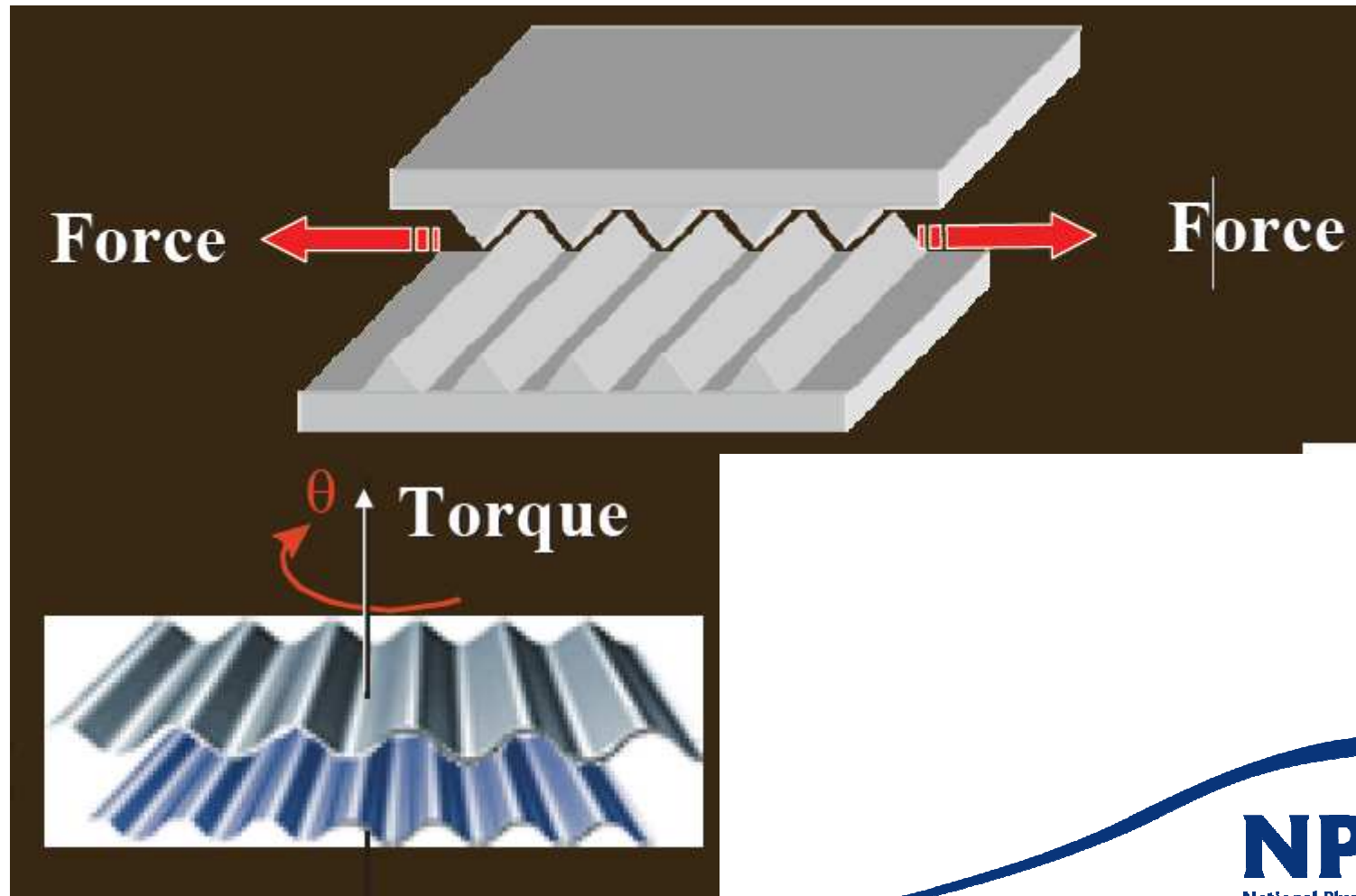

Future metrology

- Nanotube NEMS

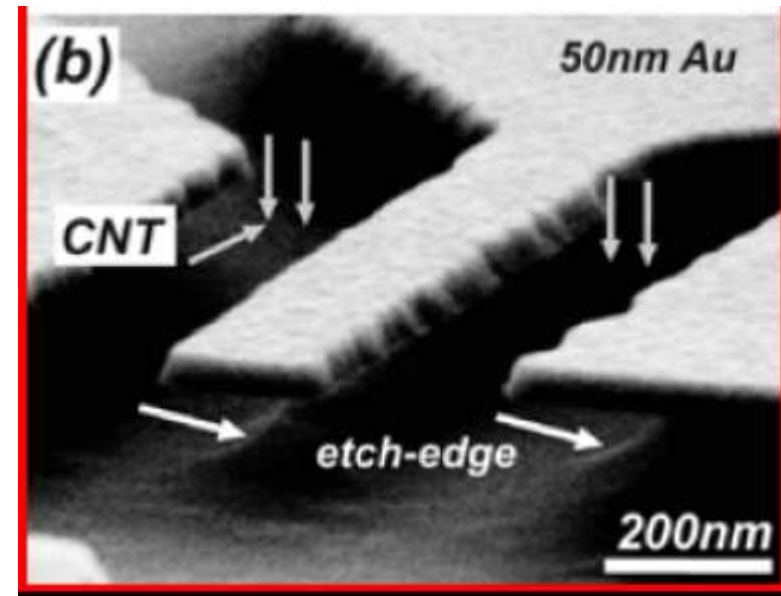
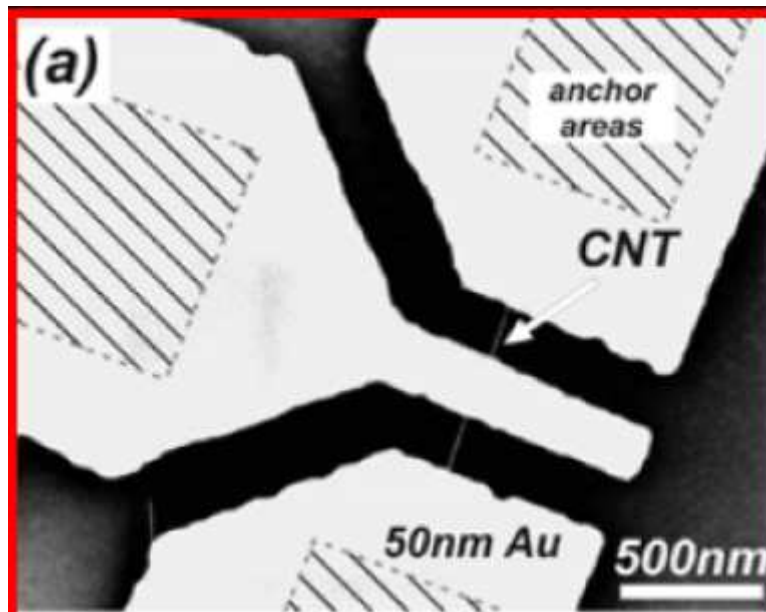

Conclusions

- Traceable force measurement and calibration essential for emerging technology
 - Ad hoc standards unsatisfactory
- NPL's Low Force Facility provides this support in the μN to nN regime
- International collaboration to benefit industry

Outlook

- 2008+ NMS Engineering Measurement Programme:
 - Formal international comparisons
 - Development of transfer artefacts
 - Usage with range of target instruments explored
 - Low force facility available to industry for bespoke measurements
- Further work:
 - Traceability in the sub-nanonewton regime?

Fundamental Principles of Engineering Nanometrology

(Elsevier, Sept 09)

by Richard Leach

(see www.amazon.co.uk)

Acknowledgements



Prof Derek Chetwynd
Knowledge input
Academic supervision



Dr Jon Pratt and team
Knowledge/experience input
International comparisons

References

Leach R K, Jones C W 2008 Towards a traceable infrastructure for low force measurements (IFIP, Volume 260, Micro-assembly technologies and applications., Springer, 307-314)

Leach R K et al. 2006 Recent advances in traceable nanoscale dimension and force metrology in the UK *Meas. Sci. Technol.* **17** 467-476

Other references available on request to richard.leach@npl.co.uk

